

GTL-FC-CP80

[30W-135W LED Surface Mount Fixture]



Description:

Die cast aluminum housing & hinged top frame, safety cable restraint, ½" coin plugs with O-rings for conduit & photocell, white powder coat finish over a chromate conversion coating. Two stainless steel latches provide tool-less entry for relamping. Molded prismatic borosilicate glass lens. Cast-in template for mounting directly over a 4" recessed outlet box, or use ½" surface conduit. ***Optional trim ring available***

Specification Features:

- CSA listed for wet locations.
- Other options and wattages and custom colors available upon request.
- UL listed Driver.
- Custom Optics available to achieve any FC level and distribution required
- Replaces up to 400 HID Lamps using 70%-80% less energy!
- Specifications subject to change without notice.

Input Voltage:

120-277VAC driver input.
 347-480VAC driver available.
 Without driver modules runs on 24VDC.

Additional Information:

Operating Temperature Range:
 -40°C to 55°C Nominal

Photometrics:
 .ies files available

Optics offered for different distributions.
 (Dist. = 120° w/o secondary optics)

Surge Protector:
 - Required for ALL 347V-480V applications in order to qualify for Warranty
 - Recommended for all outdoor applications

L70 > 150,000Hrs.

Life Sync adjusts module to operate at max performance in any given environment

Warranty: Driver = 5 years
 Solstice Light Engine = 10 years
 Fixture = 10 years

LED Module Compatibility

Product	Output Setting	LED Chip Drive Current [mA]	Rated Lumens [Lm]	Rated Watts [W]
GTSOL5498 x 1	HO	900	13164	135
GTSOL5498 x 1	HI	700	9447	95
GTSOL5498 x 1	MH	525	8999	85
GTSOL5498 x 1	ML	350	7814	75
GTSOLM21 x 1	HI	700	5910	60
GTSOLM21 x 1	MH	600	4594	50
GTSOLM21 x 1	ML	500	3742	40
GTSOLM21 x 1	LO	400	2679	30

Accessories

Catalog #	Description
CP80TR	Trim Ring for Recessed Mounting. Includes Hardware.
IP67	IP67 Rated LED Engine
GT-LSP-120	Surge Protector. 120 V 10 kA Parallel. 20kA maximum discharge current.
GT-LSP-240	Surge Protector. 240 V 10 kA Parallel. 20kA maximum discharge current.
GT-LSP-277	Surge Protector. 277 V 10 kA Parallel. 20kA maximum discharge current.
GT-LSP-347	Surge Protector. 347 V 10 kA Parallel. 20kA maximum discharge current.
GT-LSP-480	Surge Protector. 480 V 10 kA Parallel. 20kA maximum discharge current.



Fully Compliant with ARRA Buy American Requirements. Made in the USA.



Pricing Information

GTL-FC-CP80

[30W-135W LED Surface Mount Fixture]

SR16-6R1

Details

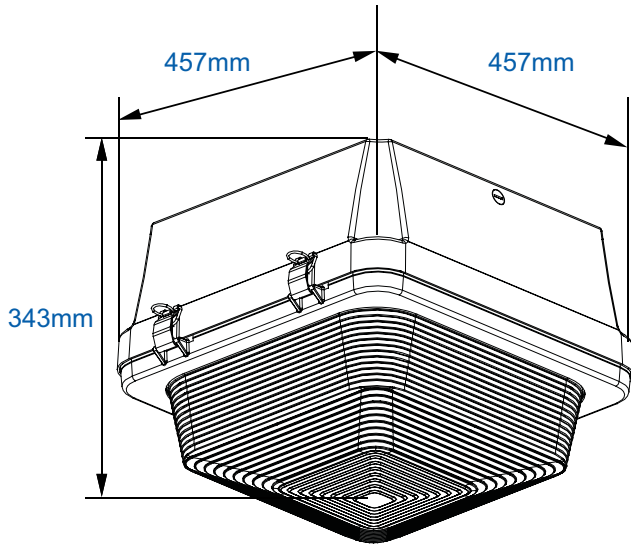

Features



- Life Sync
 - Module Temp Protection
 - Lumen Depreciation Maintenance
- Wattage Selections (on board)
- On Board Programming
 - 5-6-1 Energy Saving Program
 - 0-10V Dimming
- Lumiled Luxeon LED chips
- Active Thermal Management
- Optical Distribution Options
- -40°C to 55°C Nominal Operating Temperature
- 10 Year Warranty

Ordering Code Example:

GTL-FC-CP80 - 5498 - HI - SV - GR - NL / GT-LSP-120

Fixture	Module	Wattage	Voltage		CCT	Lens	Accs	
GTL-FC-CP80	5498	HO (135W)	SV (120V-277V)		GR (5000K) [70CRI]	NL = No Lens	CP80TR	
			HV (347V-480V)		BR (5000K) [80CRI]	10D = 10D Lens	IP67 = M21*	
	5498	HI (95W)	SV (120V-277V)		YW (4100K) [70CRI]	25D = 25D Lens	IP67 = 5498*	
			HV (347V-480V)		BL (4000K) [80CRI]	50D = 50D Lens	GT-LSP-120	
	5498	MH (85W)	SV (120V-277V)		RD (3500K) [80CRI]	75D = 75D Lens	GT-LSP-240	
			HV (347V-480V)		PR (3000K) [95CRI]	360D = 360D Lens	GT-LSP-277	
	5498	ML (75W)	SV (120V-277V)		OR (2700K) [80CRI]	360s = 360 Square Lens	GT-LSP-347	
			HV (347V-480V)		GRO (Grow)†	T2 = Type II Lens	GT-LSP-480	
	M21	HI (60W)	SV (120V-277V)		AMB (Amber)†	T3 = Type III Lens		
			HV (347V-480V)		AQU (Aquarium)†			
	M21	MH (50W)	SV (120V-277V)		RYB (Royal Blue)†			
			HV (347V-480V)					
	M21	ML (40W)	SV (120V-277V)					
			HV (347V-480V)					
	M21	LO (30W)	SV (120V-277V)					
			HV (347V-480V)					

* IP67 upgrade for module + fan (only NL, 10D, 25D, 50D & 75D)

† Upcharges not included in MSRP Price

Please see previous page for accessory information

Please note, prices may change with quantity

Fully Compliant with ARRA Buy American Requirements. Made in the USA.